

Soliton1

300kW DC Motor Controller Owner's Manual



EVnetics, LLC.
2027 4th Ave S
St. Petersburg, FL 33712
www.evnetics.com

Table of Contents

1	OVERVIEW.....	3
	Soliton1 Specs/Features.....	4
2	WARNINGS/SAFE PRACTICES.....	5
3	INSTALLATION.....	6
	Mounting & High Power Connections.....	6
	Terminal Strip Connections.....	6
4	WEB INTERFACE.....	10
	I/O Parameters	12
	Standard Operating Parameters.....	14
	Optional Operational Parameters.....	15
	Throttle Calibration.....	16
	Updating the Firmware.....	17
5	OPERATION.....	18
	Normal Operation.....	18
	Error Conditions.....	18
6	APPENDIX A – WIRING DIAGRAMS.....	19
7	APPENDIX B - TROUBLESHOOTING.....	20
8	APPENDIX C – WARRANTY/TERMS.....	21

1 OVERVIEW

The EVnetics *Soliton1* is a Series Field DC Motor Controller for electric vehicles unlike any other! Here are just a few of the unique features: the main contactors with precharge are built-in, integrated heatsink with both liquid and fan cooling, a state-of-the-art film capacitor on the input rated for *twice* the ripple current (one-half to as little as one-fifth is typical!), and an Ethernet interface that streams live performance data while allowing you to configure/update the controller with *an ordinary web browser!*

There are lots of details to consider and specs to compare when choosing a motor controller for your EV, but perhaps the most important one - that none seem brave enough to publish - is how long you can get peak motor current and how often? Unlike the typical “shoe-box” style controller with little intrinsic ability to shed heat, the *Soliton1*'s massive fan-cooled heatsink allows it to deliver 800-1000A *repeatedly*, and when liquid cooled it can deliver 1000A *indefinitely!* Other controllers may deliver a higher peak current for some brief (usually unspecified) amount of time, but none can deliver the same amount of current for the same amount of time as the *Soliton1*.
Period.

Raw power is great at the drag strip, but without the ability to precisely and safely control that power, everyday driving situations like rush-hour congestion or navigating a parking lot quickly become tedious. Unlike purely analog controller designs that struggle when motor current is below 10% of maximum, the *Soliton1*'s software randomly skips pulses (called “dithering”) to maintain precise control of motor current all the way down to 0A – no abrupt changes in frequency; no jerkiness at low speeds.

Finally, the *Soliton1* was designed by a four person team with interlocking and complementary expertise in mechanics, electronics and programming, instead of the usual “one man show”. This detail is important because rarely is one person equally skilled in all three fields. The proof is in the unique appearance and performance of the *Soliton1*.

Sebastien Bourgeois – Management/Enclosure
Jeffrey Jenkins – Hardware
Martin Persson – Software
Chris Ruoff - Enclosure

Soliton1 Specs/Features

- 342V max battery voltage with full current available at up to 300V (slight derating above that).
- 1000A current available continuously over all duty cycles with liquid cooling or for 15-20 seconds out of every 90-120 with just the included fans.
- Thermal derating reduces current at the rate of 2.5%/°C above 55°C .
- Weather-resistant enclosure with integrated heatsink and liquid cooling loop
- Microprocessor control with redundant hardware overcurrent protection.
- Main contactors *inside* the controller and precharge is handled internally.
- Rugged design based on 600V 3rd generation industrial IGBT modules.
- Special purpose high reliability/low loss 600V film input capacitor – no electrolytic capacitors to dry out and cause the controller to fail!
- High Efficiency – 1.5V max. drop at 1000A (with 0.8V typical)
- Web browser based interface – no special software needed to change settings or update the controller!
- Performance data streamed to the Ethernet port continuously for logging.
- 3-wire throttle input accepts a 0-5V signal from a pot (1k to 5k ideal), Hall effect pedal assembly, automotive “throttle position sensors”, etc. - much more versatile and safer than the older 2-wire (Curtis) “pot box”.
- Throttle controls motor current (torque) for a very natural driving feel.
- Motor current ramp rate is adjustable from a tortoise-like 100A per second to a tire-boiling 25,000A/s – performs much like traction control.
- Randomized pulse-skipping (“dithering”) maintains precise control of motor current all the way down to 0A for smooth starts and easy low speed driving without annoying whines and squeals.
- Switching frequency in Performance mode is 8kHz (for lower switching losses and is usually silent) while in Quiet mode it is 14kHz.
- All low voltage connections protected against reverse polarity, spikes and treat 5V as maximum but tolerate 15V for convenience.
- Tachometer input (1, 2, 4, 6, 8 pulses per revolution) for protecting against overspeed and idling automatic transmissions, a/c compressors, etc.
- Brake input - overrides throttle when active for added safety.
- Reverse input – separate limits motor voltage and current when in reverse.
- Three programmable inputs (analog/digital) for future expansion.
- Three programmable outputs for driving contactors, analog meters with PWM (digital meters with appropriate RC), and future expansion.
- Fault output can directly drive the “Check Engine” light in the dash.
- Low pack voltage limit protects batteries against over-discharge while maximizing range by limiting motor current to whatever amount keeps the pack voltage above the programmed limit (limp-home mode, in essence.)
- 3D drawings for planning installation ahead of time available.
- And many other functions and features both implemented now and scheduled for future upgrades...

2 WARNINGS/SAFE PRACTICES

It takes substantial mechanical and electrical skills to be able to convert your own vehicle – if you do not possess the necessary experience (wouldn't know a volt from an amp, or an open end from box head) then we *strongly* encourage you to seek out the services of a qualified conversion shop! If you feel you are up to the task then always keep the following in mind:

- **High DC voltage can kill you!** Treat anything above 60V DC as potentially lethal because it can cause muscles to lock involuntarily.
- **EV-size batteries can deliver extremely high short circuit currents!** They are easily capable of *vaporizing* a wrench, for example.
- **Never ground the traction battery pack to the vehicle frame!** What is okay in a 36V golf cart is *not okay* in a high voltage DC electric vehicle.
- **Insert at least one Class T fuse into the battery pack circuit!** You can insert manual disconnects and/or circuit breakers as well, *but keep the fuse!*
- **Know and respect your motor's power limit!** Most motors can tolerate maximum current or maximum voltage, but not both at the same time!

Please refer to the Limited Warranty and disclaimers of liability at the end of this document or at: <http://www.evnetics.com/termsandconditions.html>

3 INSTALLATION

Mounting & High Power Connections

The first installation consideration is where to mount the *Soliton1* and there are a number of factors that go into that decision. While the *Soliton1* is weather-resistant by design, it should still be mounted where it will not be rained on, immersed or subject to direct spray. If you are not using liquid cooling then also try to orient the controller so that the fins point upward and/or are oriented vertically. If you have to mount the controller with the fins horizontal and/or pointing down it will run hotter, perhaps beyond the ability of the built-in fans to allow very high performance in daily driving. Also be mindful of the weight (15kg/33lbs) when choosing a mounting location and fastening method.

There are separate battery (*B*) and motor (*M*) connections and they are *not* interchangeable. That is to say, please connect the traction battery to the Battery terminals and the motor to the Motor terminals. The precharge circuit will protect against accidentally reversing the battery connections, but accidentally connecting the battery cables to the motor side terminals will likely be warranty-voiding fatal (so, make extra sure you connected everything correctly!).

The battery and motor studs are 1/2" in size to handle high sustained currents. The recommended size of the battery cables is 2/0 while for the motor cables 2/0 to 4/0 should be used. At least one Class T fuse should be in the battery circuit – because of the time versus current rating of this fuse class (I^2t), a 400A fuse will generally be used to protect 2/0 wiring – your installation may vary. To minimize radiated noise, **keep the battery cables as close to each other as possible** (even better is to twist them together and yes, this is perfectly possible with welding cable). The motor cables, which will carry a much higher average current, should simply be kept as short as possible.

Terminal Strip Connections

The terminal strips on the side of the controller (See Illustration 1) are for low voltage connections only and are totally isolated from the traction battery (**DO NOT APPLY PACK VOLTAGE TO ANY TERMINAL ON THESE TWO STRIPS!**). Broadly speaking, the 6-terminal strip is for “power” connections while the 10-terminal strip is for “signal” connections. Notice that there are separate signal grounds on the 10-terminal strip – using these terminals for the throttle and tachometer, in particular, will vastly reduce the chances of picking up electrical noise.

All inputs respond to 0V to +5V with respect to signal ground but are 15V tolerant – that is, internally clamped to 5V. For example, you can connect the BRAKE input directly to the brake light wire. All outputs deliver +12V at up to 1A when active and revert to a high-impedance state when off so you need to connect any loads between an output and vehicle ground (or GND, of course). The outputs are protected against

short-circuits, reverse-polarity, and inductive-kickback but do at least make an effort to wire things up properly the first time!

The *Soliton1* operates on +12V nominal which is supplied to the IGN terminal, usually from the ON position of the original ignition switch (hence the name). Connect GND to the negative terminal of the 12V battery, or to the vehicle frame to complete the circuit. The maximum continuous current draw is 1A, not including any any loads driven by the auxiliary outputs. The operating voltage can range from 11V at the low end to 15V at the high end. If the voltage drops below 11V the red LED and ERR output will flash to indicate a problem. If 10V or 15.5V is breached even momentarily the controller shuts down. The internal circuitry is protected against accidental overvoltage, but it will be damaged if exposed for more than a few seconds. Please ensure the 12V power supply is stable first!

The only other connections that must be made are for the throttle. The THROTTLE input responds to a 0-5V signal, with 5V considered “full throttle”, and so it is compatible with a wider range of transducers than the older 0-5k input. You can use a potentiometer (pot), Hall effect pedal assembly (HEPA), etc., or any other transducer for a throttle as long as its output voltage is proportional to throttle position (ideally, with a linear response, but logarithmic is fine, too). A stable, protected source of +5V (SIGNAL+5V) is provided on the terminal strip to use either as a reference voltage or to actually



Illustration 1: terminal strips



Illustration 2: EVnetics throttle transducer

provide power for the throttle transducer. If using the EVnetics Throttle Transducer (See Illustration 2), or similar high quality pot, simply connect the full throttle end (red wire) to the SIGNAL+5V terminal and the zero throttle end (black/shield wires) to SIGNALGND (to avoid picking up noise, do NOT connect either the pot or this terminal to the vehicle ground) and the wiper (white wire) to THROTTLE. If using a HEPA, connect the +5V terminal to SIGNAL +5V, the output terminal to THROTTLE and the ground terminal to SIGNALGND. If the wiring run between the throttle transducer and the *Soliton1* is more than 1m (~3') then consider the use of shielded cable, such as Radio Shack part # 278-0513, and connect the shield to SIGNALGND. **WARNING** - the popular Curtis PB-6 “pot box” is *not* compatible with the *Soliton1* as-is because it is wired as a variable resistor – you can modify the PB-6 back to a pot or use a pullup resistor between THROTTLE and SIGNAL+5V, but the latter is strongly discouraged! Please refer to Appendix A – Wiring Diagrams for more information.

The other terminals do not need to be connected for the *Soliton1* to function but can greatly enhance the utility and safety of an EV if used:

BRAKE – splice a wire from the brake lights to this terminal to shut down the motor output when the brake lights turn on, even if the throttle is not at zero. However, just to facilitate doing burnouts, if you let throttle return to zero while the brakes are applied, you can then reapply throttle.

IN1-3 – programmable inputs, one of which is REVERSE. As with BRAKE, splice a wire from the reverse lights to said input to reduce power whenever the vehicle is in reverse (0-5V analog signal range and tolerant of up to 15V).

OUT1-3 – programmable outputs for driving meters (see Appendix A), contactors, relays, buzzers, etc., as long the device runs on 12V nominal and uses less than 1A (each).

TACHOMETER – this input accepts pulses (amplitude of 4V to 15V) from a wide variety of transducers to read the motor RPM (overspeed protection and idle can't work without it). On our dyno we use a generic industrial inductive proximity (“prox”) sensor with a NPN open collector (OC) output that requires a “pullup” resistor from TACH to



Illustration 3: inductive prox on our dyno

the positive supply. PNP OC outputs can also be used – they just need a “pulldown” resistor, from TACH to ground - and in some ways are preferred for immunity to noise. Industrial inductive prox sensors are robust and inexpensive (less than \$20 from such online merchants like Automation Direct). Try to use the lowest practical value of pullup (or pulldown) resistor possible to minimize the effects of noise from the battery cables. Our prox sensor recommended a minimum value pullup of 150 ohms, which is almost the maximum current available from the SIGNAL+12V terminal of ~80mA). Inductive prox

sensors detect the presence of any kind of metal, magnetic or not, and are much more resistant to stray magnetic fields (like from a big DC motor nearby!) than Hall Effect prox sensors. Optical sensors (either retroreflective or interrupter style) are also good choices *if* not subject to getting caked up with dirt and/or can be easily cleaned. Illustration 3 shows how we used an inductive prox to detect the passage of a stainless steel bolt head on our dyno. It works well, but we probably should have sprung the extra few dollars for the version with shielded cable as the noise-detecting algorithm in the code is rejecting 8-10 pulses per 100ms sampling interval.

Liquid Cooling

Liquid cooling is built-in to the heatsink and can be a real benefit in keeping the *Soliton1* out of thermal limiting, especially in hotter climates (like where we are, St. Petersburg, FL!) and/or where higher average power is demanded of the controller (such as heavier conversions or in hilly terrain). We strongly recommend that a 50/50 mix of aluminum-safe coolant and water be used to protect against corrosion. Only 1-2 GPM (4-7 LPM) of flow rate is needed and the system pressure should not exceed 5 PSI so impeller (centrifugal) pumps as used for bilges, computer cooling systems, etc., are ideal. The cooling loop should either have a sump with air-gap or a Tee fitting at the highest point in the system to eliminate trapped air. The barbed fittings that come with the controller are for 1/4" ID hose but if you want to replace the fittings ports are tapped 1/8"-27 NPT. Notice the use of hose clamps in Illustration 4 - do not rely on the barbs alone to hold the hose in place!



Illustration 4: liquid cooling connections

4 WEB INTERFACE

Configuring the *Soliton1* couldn't be easier. You only need a laptop with an ethernet port and a web browser – no special OS, software or cables required.

For Microsoft Windows®

The *Soliton1* is compatible with the automatic private IP functionality in Windows (DHCP) that is usually enabled by default. Connect the *Soliton1* and laptop together with an ethernet cable, wait 1 minute for DHCP to recognize the connection, then enter <http://169.254.0.1/> into your web browser's address bar. If your browser displays a “404” error it's probably because you didn't wait long enough – just click on the “Try Again” button or refresh the page. When you are done simply disconnect the ethernet cable – no changes to your computer's configuration, need to be reversed.

For all other OS (Linux, MacOS, etc.) or if DHCP is disabled

In contrast, you will have to make some changes to the network configuration if using a non-Windows OS or have disabled DHCP in Windows. First note your laptop's current settings for IP address and netmask and then change them, respectively, to 169.254.0.2 and 255.255.0.0 – the gateway and DNS server fields should have nothing entered into them but if there is, then note those entries and then clear them out. Now connect the controller and laptop together with an ethernet cable and enter http://169.254.0.1 into your web browser's address bar. Making these sorts of changes to the network configuration will likely prevent you from accessing the internet, so when you are done tinkering with the settings in the *Soliton1*, restore the original network configuration if necessary.

Once you have successfully connected to the *Soliton1* you will see a web page similar to the one shown on the following page. As new functions are added to the software this page will change and this manual will be updated – older versions of this manual, named according to the software revision, will remain available at:

<http://www.evnetics.com/download/>



evnetics

controller interface

Model:	Soliton 1
Serial number:	12-09-1025
Software version:	1.1rc400 (Dec 08 2009)
Current controller mode:	Running
Throttle (min/max):	0/100 %
CPU usage:	24 %
RAM usage:	43 %

Power mode	<input type="text" value="Performance"/>	Input 1	<input type="text" value="Off"/>	Output 1	<input type="text" value="Off"/>
Brake input	<input type="text" value="Off"/>	Input 2	<input type="text" value="Off"/>	Output 2	<input type="text" value="Off"/>
Tachometer	<input type="text" value="Off"/>	Input 3	<input type="text" value="Off"/>	Output 3	<input type="text" value="Off"/>

Minimum battery voltage (9-300 V):	<input type="text" value="100"/>
Maximum battery current (10-1000 A):	<input type="text" value="400"/>
Maximum motor voltage (9-340 V):	<input type="text" value="150"/>
Maximum motor current (50-1000 A):	<input type="text" value="800"/>
Maximum motor power (20-300 kW):	<input type="text" value="100"/>
Slew rate (100-25000 A/s):	<input type="text" value="500"/>

Throttle deadband (0-50 %):	<input type="text" value="0"/>
Half throttle current (10-50 %):	<input type="text" value="50"/>

Disable the controller for upgrades and throttle range calibration.

© 2009 evnetics

Illustration 5: controller interface home page

Items that are grayed out will be implemented in later code releases. A brief overview of each section in the web interface follows with detailed explanations of the actual parameters/fields as appropriate.

Blue box: basic information and controller status.

- *Model, serial number* and *software version* are self-explanatory
- *Current controller mode* is the status (listed later)
- *Throttle (min/max)* lists the calibration points for full off and on
- *CPU and RAM usage* should both be under 50%
- *Factory defaults* reset all parameters globally – not yet implemented

First block: input and output functions.

- *Power mode* – selects between 8kHz (Performance) and 14kHz (Quiet)
- *Brake* – optional input; shuts down motor output when active (high or low active)
- *Tachometer* – optional input;(described in detail later)
- *Inputs 1-3* – optional; programmable functions
- *Outputs 1-3* – optional; programmable meter and contactor drivers

Second block: operating parameters. Some will only appear if the relevant input functions are selected. Most of these settings are used to reduce the power output when the relevant limit is breached and will be explained in detail later.

Third block: throttle calibration and code updating. Click on “Disable controller” to access both functions. You may never bother to update the code, but you almost assuredly will have to calibrate your throttle!

I/O Parameters

In this block you configure the behavior of the fixed and programmable inputs and outputs on the *Soliton1*.

Power Mode – technically not an I/O setting, this lets you choose between a switching frequency of 8kHz (Performance) or 14kHz (Quiet). The lower frequency greatly reduces switching losses and radiated electrical noise, but in some installations may result in audible noise from the motor (usually only at low currents). The higher frequency not only eliminates switching noise from the motor, it also reduces the ripple voltage across the traction battery. The downsides are that the higher frequency results in more radiated electrical noise (which is always helped by twisting the battery cables together) and much higher losses in the controller (i.e. - it reaches thermal limiting faster and range will be reduced slightly).

Brake input – when activated this tells the *Soliton1* to immediately reduce motor current to zero, regardless of the throttle setting. Recognizing man's eternal love for power burnouts, throttle can be reapplied after it is returned to zero as long as the

brake input stays active the entire time. This behavior may have to be modified to comply with safety standards. Note that you can select whether this input is activated by a high ($\geq 5V$) or low (0V) signal for maximum flexibility. Connect this input to the wire that goes from the switch on the brake pedal to the brake lights.

Tachometer – selects the number of pulses per turn (1, 2, 3, 4, 6, 8) with 2 – 4 ppt ideal. With 1 ppt there is such a long delay between pulses that idle (if enabled) is rough and overspeed protection will overshoot significantly (e.g. - by as much as 1000 rpm) while with 6 and 8 ppt the RPM resolution becomes coarse and limited in the top speed it can read (4250 and 3750 rpm, respectively). Note that the 6 and 8 ppt selections may be dropped in the future.

Inputs 1-3 – Programmable inputs that can read a 0-5V linear signal or a switch connected to either +5V or +12V (tolerant of up to 15V) as a digital HIGH.

Outputs 1-3 – Programmable outputs that are mainly used to drive analog meters (or digital ones with some additional circuitry) to display various operating parameters that many EV drivers may find useful such as Battery Pack Voltage, Motor Current, Motor Power and estimated State of Charge. A linear output is synthesized by varying the duty cycle from 0% to 100% at a frequency of 60Hz, which an analog meter will automatically integrate. Gauges that read a grounded resistive transducer – such as a fuel gauge – can use the simple circuit shown in Illustration 6.

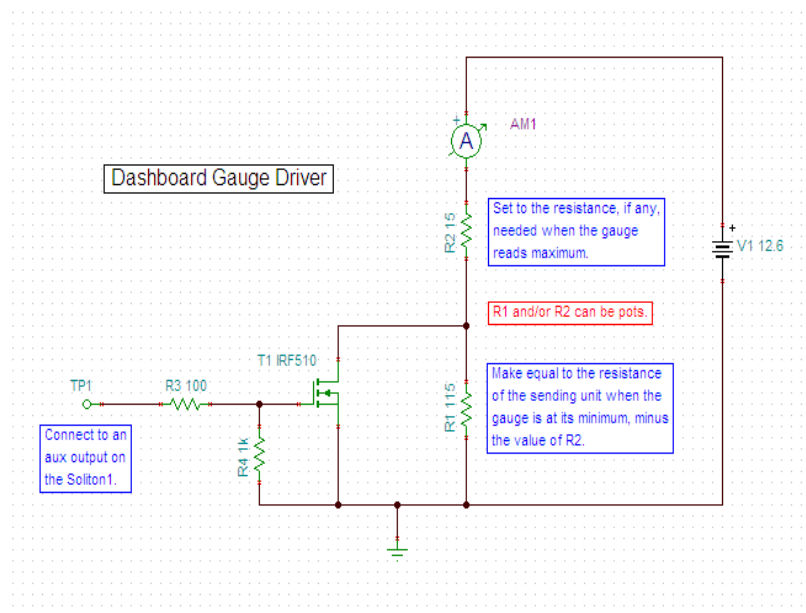

Illustration 6: automotive gauge driver

Standard Operating Parameters

These are the settings that need to be changed to suit your particular setup and while most of the settings are self-explanatory, there are some subtle details to each which will be addressed here.

Minimum battery voltage (10V-300V) - This protects against over-discharge of your traction battery pack by limiting power when its voltage drops down to this limit. For Lead-Acid batteries try setting this to 10V - 10.5V per 12V battery (1.5V - 1.75V per cell) unless you are drag racing. For Lithium Iron Phosphate (“LFP”) cells try 2.6V or 2.7V per cell (some go as low as 2.5V); e.g. - a 60 cell pack with a nominal voltage of 192V should be set to 156V, whether you are drag racing or not.

Maximum battery current (10A to 1000A) - In all cases you should consult the battery manufacturer's technical literature for the recommended maximum discharge rate (usually given in multiples of the 1 hour rate, “1C”), but absent that info the typical settings for the more common battery types will be given here. For high performance VRLA, AGM and flooded lead acid batteries 6C-10C is possible while gel-cell batteries should probably be set to no more than 4C (e.g. - for 105Ah gels set this to 420A max). Prismatic LFP cells can deliver 3C to 4C (e.g. - 600A to 800A for 200Ah cells) for long durations. Flooded NiCd and large format NiMH chemistries can deliver as much as 10C for several seconds, but you need to know the 1C rating first!

Maximum motor voltage – (9V to 340V): this can help prevent excessive brush arcing or even flashover (colloquially called “zorching”). Please note that the actual voltage a motor can withstand depends on the temperature, current, build-up of carbon dust, whether the brushes are seated to the commutator, etc. In other words, it's hard to make a hard and fast recommendation here. In general, though, you can't run a motor at its maximum voltage and current at the same time, but it's usually preferable to run more current than voltage, so start out at about 3/4th the maximum rated motor voltage for this setting.

Maximum motor current – (50A to 1000A): this one gets more explanation than you might expect is needed. First keep in mind that all motors, whether explicitly stated or not, are rated for a certain amount of current *for a certain amount of time*. For example, the NetGain WarP® series of motors have the following ratings:

2000A	10 seconds
1000A	20 seconds
500A	5 minutes
225A	1 hour

In the absence of any specific data from the motor manufacturer (e.g. - surplus or refurbished forklift motor), you can typically exceed the “1 Hour” current rating stated on the data-plate by 4-5x for as long as 20 seconds, but you really ought to pay attention to the amount of sparking at the commutator to make sure flashover isn't imminent. Also, neutrally-timed motors that are wound for higher voltages generally don't take the same amount of overcurrent (e.g. - Kostov, D&D) as those wound for

36/48V and with advanced brush timing. This is something we have learned from experience, by the way.

Maximum motor power – (20kW to 300kW): this limit works as a “sanity check” in conjunction with the other two motor limits. In general, it's the most useful one to set because it is total motor power that causes the brushes to flashover, not just high amperage or voltage. We recommend sticking with the default of 100kW unless you have a dual motor setup and/or some means of monitoring the motor temperature.

WARNING – The power output of the *Soliton1* is more than capable of destroying any single motor, even when it is only air-cooled (this is a serious warning, not just advertising hype). If you set maximum motor current to 1000A then you *must* pay attention to how long you apply full throttle: doubling motor amps from 500A to 1000A results in a 15x decrease in allowed time!

Slew rate (A/s) - (100A/s to 25000A/s) this sets the rate at which motor current will rise (but not fall) to the value commanded by the throttle position. It is in increments of 100A/s (e.g. - at 1000A/s it will take 1 second to hit 1000A if starting from 0A). The default setting of 500A/s is responsive without being jumpy, but lighter vehicles, especially with automatics (because of the torque converter), might behave more smoothly with a lower setting (e.g. - 300A/s). Be careful when exceeding slew rates of 1000A/s because the risk of breaking stuff like clutches, transaxles, driveshafts, motor mounts, etc. goes up dramatically.

Optional Operational Parameters

If any of the optional inputs are enabled then their associated parameters become available on the web interface. The screen capture shows the full suite of operational parameters (and the default settings) with all currently available input options enabled:

Power mode	Performance	Input 1	Motor temp sw.	Output 1	Off
Brake input	Off	Input 2	Reverse	Output 2	Off
Tachometer	2 pulses/turn	Input 3	Off	Output 3	Off

Minimum battery voltage (9-300 V):	100
Maximum battery current (10-1000 A):	400
Maximum motor voltage (9-340 V):	150
Maximum motor current (50-1000 A):	800
Maximum motor power (20-300 kW):	100
Slew rate (100-25000 A/s):	500
Maximum motor speed (2000-8000 RPM):	5000
Idle motor speed (0, 500-1500 RPM):	700
P (0-100%):	30
I (0-100%):	20
D (0-100%):	30
Maximum motor current at overheat (50-1000 A):	200
Maximum motor voltage at reverse (9-300 V):	48
Maximum throttle at reverse (10-100 %):	50

Illustration 7: optional parameters

Maximum motor speed (RPM) – (2,000 to 8,000 RPM) if *tachometer* is enabled this cuts motor power at the specified RPM to protect against overspeed. Check with the motor manufacturer for its max rated RPM, but in general a 9" motor should be set at 6000, an 11" at 5000 and a 13" at 4000.

Maximum motor current at overheat (A) – (50A to 1000A) if *motor temp sw.* is enabled then this setting determines the max motor current allowed when the motor is too hot. Active high.

Maximum motor voltage at reverse (V) – (10V to 340V) this setting is very important to prevent flashover if electrically reversing an advanced timing motor (by flipping the polarity of the field terminals with two contactors). If you use the vehicle transmission for reverse this setting is less important, but still useful for limiting the motor's speed.

Maximum throttle at reverse (%) - (10% to 100%) this should be used regardless of whether reverse is implemented electrically or mechanically (i.e. - by shifting the transmission); it simply limits full throttle to a percentage of the maximum motor current value. For example, if set to 50% then full throttle in reverse will be cut in half.

Idle Parameters

Idle is a new feature for the *Soliton1* which can make driving an EV with an automatic transmission much less painful, but there are a few parameters that can wreak havoc if they aren't set carefully. Idle relies on a "PID" loop to be able to maintain a set RPM whether the load changes slowly (e.g. - as the transmission fluid heats up to operating temperature) or quickly (e.g. - from the power steering pump) or abruptly (e.g. - the a/c compressor kicking on). Idle relies on some sort of motor speed sensor ("tachometer"), of course, and best results are obtained with sensors that produce 2 to 4 pulses per turn. For safety reasons, the *Soliton1* does not begin idling the motor until the throttle has been "blipped" enough to spin the motor faster than the idle RPM setting. This feature is required for EVs because an electric motor will happily produce torque all the way down to 0 rpm, whereas an IC engine in the same situation will stall, so if idle were to be engaged with a manual transmission that is in gear the car could/will start moving! Another safety feature of idle is that motor current is limited to 300A – this is just enough to give good response to abrupt load changes, but much more than is typically needed to maintain a steady RPM.

Idle motor speed (0, 500-1500 RPM) – Set to 0 to disable idle, otherwise, set to between 500 and 1500 RPM. Most modern vehicles idle at around 600-800 rpm so if you are transferring all of the OEM accessories and maintain the same pulley ratios then set idle to the whatever RPM was specified for the original IC engine.

PID Loop Parameters

Be careful changing these! We highly recommend starting with the suggested settings for each parameter and only changing them by 1 point and only one at a time if you do want to tweak them. These settings affect the responsiveness of the idle speed regulation loop which also affects its stability. Inappropriate settings here could cause motor's speed to oscillate like crazy.

P – Recommended initial setting is 30. This sets the proportional gain for the loop.

I – Recommended initial setting is 20. This sets the integral gain, which attempts to correct the steady state rpm error. Can cause instability if increased or large errors in RPM if decreased.

D – Recommended initial setting is 30. This sets the derivative gain, which sets how quickly the loop reacts to abrupt changes in RPM. This can definitely cause instability if increased too much (the best way to test this parameter is to turn the A/C on and off).

Throttle Calibration

The first time you power up the controller, even if all connections were made properly, you might be greeted with a solid red error light because the throttle is not in the off (zero) position. No problem – just connect a laptop to the controller with a standard ethernet cable, surf over to the controller's web page (<http://169.254.0.1/>) and hit the "Disable controller" button. Go back to the home page and you'll see it has changed status to say "Stopped by user" and some new fields are now available.

Throttle deadband (0-50 %):	<input type="text" value="0"/>
Half throttle current (10-50 %):	<input type="text" value="50"/>
Invert throttle input (5-0V):	<input type="text" value="Normal (0-5V)"/>

Illustration 8: throttle calibration

Click on “Calibrate min throttle” to store the current throttle position as “zero”. Hit back to return to the home page, apply maximum throttle, and then click “Calibrate max throttle” to store the full throttle position. Click on “Back” and your done.

Throttle deadband (%) - specifies how much throttle voltage from the calibrated zero point is still treated as zero. It is primarily used to compensate for Hall effect pedals that tend to drift “on” with temperature. Setting this value to 5%, for example, tells the *Soliton1* to ignore a throttle voltage increase of up to 5 percentage points. In general, it doesn't hurt to set this to a small number (2-5%) regardless of the throttle type.

Half throttle current (%) - specifies what percent of the maximum motor current the *Soliton1* will attempt to deliver when the throttle voltage is at it's calibrated midpoint. For linear and logarithmic throttles, leave this at the default of 50%. For finer control of the motor at low currents, or if your throttle behaves “anti-logarithmically”, you can reduce this number.

Invert throttle input – motor current is proportional to throttle voltage by default, but can be set to operate inversely. For safety reasons, the *Soliton1* treats 0V in this case as a “broken throttle wire” fault. If there is a choice we strongly recommend not using throttles with an inverse proportional behavior, but we have found that in some newer vehicles with drive-by-wire throttles, and when re-using the servo-driven TPS (throttle position sensor) this is unavoidable.

Updating the Firmware

The program that runs on the microprocessor inside the *Soliton1* consists of nearly 5000 lines of C code and it is a real work of art. Just like any other art work, though, it is never really finished! So, as we come up with new functions, features and, even, the occasional bug-fix, we will release code updates on our website at www.evnetics.com/downloads/ that will be named, e.g., *soliton1_1v1.txt* (for “full release” code version 1.1).

To update, click on “Disable controller”, then “Browse” to specify the file, then “Update” to transfer the file. It will take 40 seconds to 4 minutes (!) to complete the transfer. Once the red and green lights stop flashing, simply cycle the power to the *Soliton1* and the bootloader program will check the integrity of the file then write it to

the microprocessor's memory if it passes, or erase it if it fails (no risk of corrupting the controller).

Alternatively, the *Soliton1* can be updated directly – without loading up a web browser, that is – with the *uploader_xxx.exe* program (where 'xxx' is replaced with the version number such as 'b400' for betas or '1r1' for a full release). There are a couple of advantages to this method: it updates much faster (because it bypasses a couple of “quirks” in Windows' TCP/IP stack) and you don't have to remember the web address for the *Soliton1*.

5 OPERATION

Normal Operation

Operating an EV with the *Soliton1* controller is very simple: just turn the ignition switch to ON, wait for the red “Error” light to turn off and go. If you are impatient and step on the throttle pedal before precharge is completed, just release the pedal and *then* you can go. Obviously, having the error light visible inside the vehicle interior makes this process simpler (e.g. - by connecting the former “Check Engine” light to the ERR terminal).

Error Conditions

The *Soliton1* divides errors into three groups: slow blink, fast blink and continuous, which nominally correspond to four types of errors:

Temperature - if the heatsink is above 55C (131F) then the error light will blink slowly (every 2.7 seconds). Full throttle motor current will be reduced at the rate of 2.5%/C (i.e. - down to 0A at 95C).

RPM - the error light also blinks slowly if motor RPM limiting is in effect.

Voltage - two different errors fall under this heading, but they both cause the error light to blink quickly (3 times per second):

- Ignition (Aux) voltage below 11V (controller is disabled at 10V)
- Battery pack at low voltage limit (controller is disabled if pack voltage declines more than 10V from this limit, to force precharging again).

Disabling – several errors fall under this heading all of which result in the main contactors being dropped and the error light staying on continuously:

- Ignition (Aux) voltage at 10V or below – this protects against destroying the IGBTs from too little gate drive – even a momentary dip below 10V will trigger this fault. EVnetics recommends using a DC-DC converter to keep the 12V battery charged.
- Aux voltage too high – IGN terminal at or above 15.5V. Zener clamps protect against this condition but they will overheat if subjected to overvoltage for more than 20-30 seconds.
- Battery pack more than 10V below programmed limit – cycle power to go through precharge again because a 10V difference in voltage between the capacitor and the battery pack will result in ~1000A of inrush current.
- Throttle not in zero position – calibrate throttle or check wiring. If throttle was calibrated, increase the deadband setting.
- Desaturation error – a short circuit or other extreme overcurrent condition (more than ~1600A) was detected (see TROUBLESHOOTING below)
- Intentionally disabled by clicking on the “Disable controller” button.
- Other errors that should never occur – See TROUBLESHOOTING below.

6 APPENDIX A - WIRING DIAGRAMS

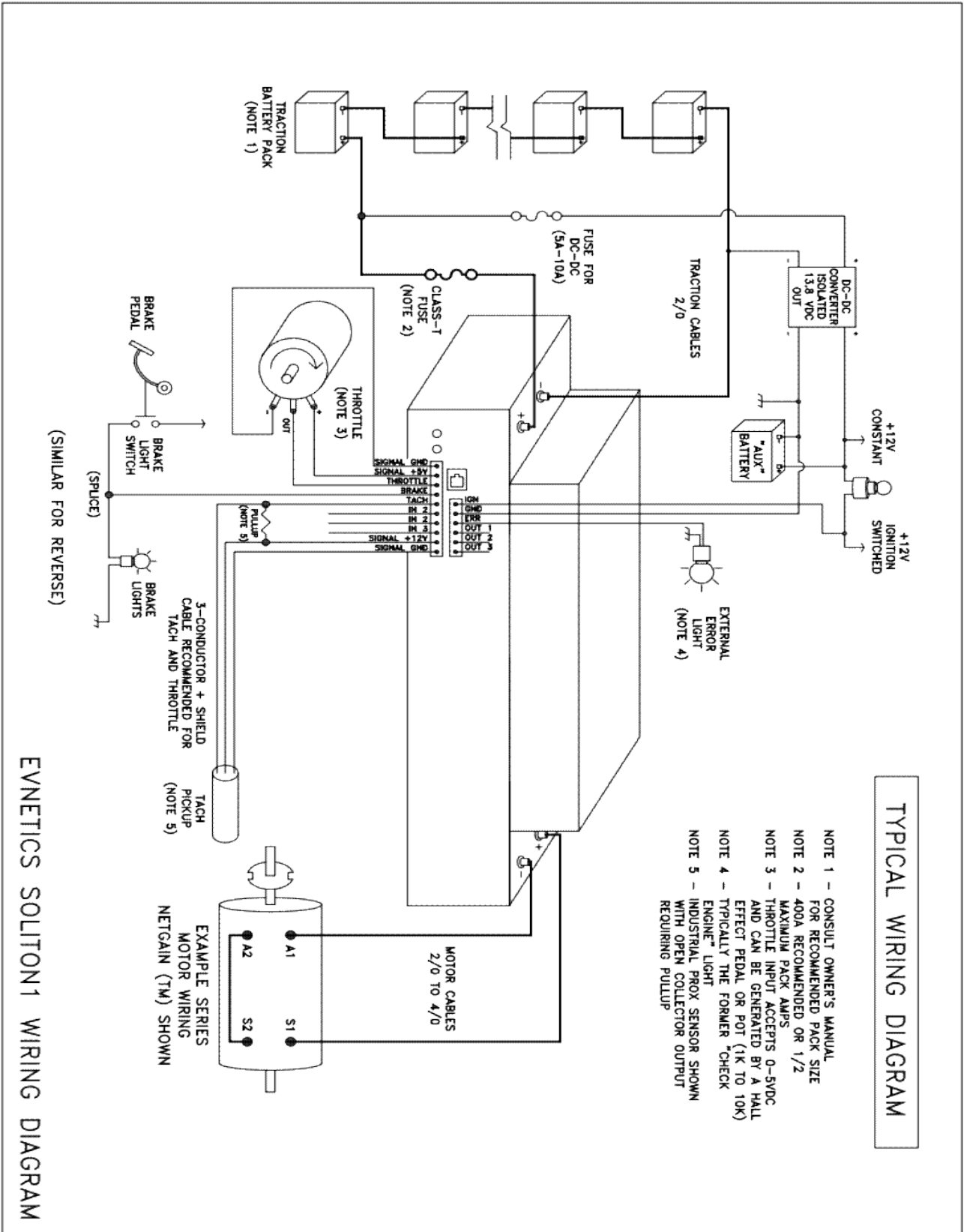

7 APPENDIX B - TROUBLESHOOTING

Status/Fault Codes

Starting up – rarely seen in a Windows® system.

Precharging - ditto

Throttle not in zero position – calibrate min. throttle position.

Running - normal

Aux voltage too low – 12V power below 10V (check battery!)

Aux voltage too high – 12V power supply above 15V (check DC-DC converter!)

Battery voltage too low – traction pack voltage more than 10V below setpoint

Stopped by user – controller is ready for a code update or throttle calibration

Desaturation error – Please contact EVnetics if you ever see this!

Software error – Same with this error...

Memory low – ...and this one...

Unknown problem - ...and this one!

Parameter Ranges

Min pack voltage: 9-300 (V)

Max pack current: 10-1000 (A)

Max motor voltage: 9-1000 (V)

Max motor current: 50-1000 (A)

Slew rate: 100-25000 (100 A/s steps)

Max motor RPM: 2000-8000 (RPM)

Idle RPM: 500-1500 (RPM)

Max motor current for overheated motor: 50-1000 (A)

Max motor voltage for reversed motor: 10-1000 (V)

Max throttle for reversed motor: 10-100 (%)

Extra deadband: 0-50 (%)

This section will be expanded once problems are actually reported from the field. We did an extensive beta testing program so you wouldn't have to!

8 APPENDIX C – WARRANTY/TERMS

LIMITED WARRANTY

Please refer to the full Terms & Conditions page on the EVnetics website at:

<http://www.evnetics.com/termsandconditions.html>

The bulk of the Limited Warranty section is reprinted below. Please understand that in a world where one can be sued for getting burned by hot coffee, we have to put a lot of legalese into this section as an EV motor controller is substantially more dangerous.

Limited Warranty and Conditions: EVnetics, LLC warrants that its products substantially conform to the listed technical product specification at the time of purchase. Under applicable law, EVnetics, LLC, its employees, members, officers or directors, agents, successors or assignees shall not be liable to anyone under any product order, schedule or terms and conditions herein under any contract, strict liability, tort (including negligence) or other legal or equitable theory, whether or not foreseeable or foreseen, for: (a) business interruption costs, cost of rework, retesting, procurement of substitute goods, removal and reinstallation of goods; or (b) any special, incidental, exemplary, indirect or consequential damages, including without limitation loss of life, bodily injury, lost profits, litigation costs, loss of data, production or profit, goodwill, loss of revenue, or loss of units; regardless of whether seller has been advised of the possibility of such damages, there is a total and fundamental breach of this agreement or whether any remedy provided herein fails of its essential purpose.

The limit of liability for any claims shall not exceed the amount paid or prepaid on account by buyer for the goods giving rise to such claims. Buyer shall be deemed to assume all liability for any and all damages arising from or in connection with the use or misuse or installation or handling of the goods by buyer, its employees, customers and others.

Seller shall not be liable for and buyer agrees to indemnify, defend and hold seller harmless from any claims based on seller's compliance with buyer's designs, specifications or instructions, or modification of any goods by parties other than seller or manufacturer, or use in combination with other products.

To the fullest extent permissible pursuant to applicable law, EVnetics, LLC. disclaims all warranties, express or implied, including, but not limited to, implied warranties of merchantability and fitness for a particular purpose.

Working on automobiles is inherently dangerous, especially electric ones. EVnetics, LLC. is not liable for injury or damage due to the installation or use of their products. All products are sold with the understanding that the safe and proper installation and use of the products is the customer's responsibility. Follow factory workshop and industry manual procedures and instructions, but use current shop safety standards and common sense. Some tasks will require professional advice or services which EVnetics, LLC cannot provide.

EVnetics, LLC. shall not be liable for any direct, indirect, incidental, special, consequential or exemplary damages, including but not limited to, damages for loss of profits, goodwill, use, data or other intangible losses resulting from: (i) the use or the inability to use the service; (ii) the cost of procurement of substitute goods and services resulting from any goods, data, information or services purchased or obtained or messages received or transactions entered into through or from the service; (iii) unauthorized access to or alteration of your transmissions or data; (iv) statements or conduct of any third party on the service; or (v) any other matter relating to the service.

For any such Products, this warranty shall be effective from the date of delivery until twelve (12) months thereafter (the "Warranty Period"). Notwithstanding anything to the contrary herein, no warranty for any Product shall be enforceable in the event that the Product has been subjected to environmental or stress testing by Buyer or any third party without written approval of EVnetics, LLC prior to such testing,

or if the alleged defect or nonconformity cannot be verified or reproduced by EVnetics, LLC, or is a result of abuse, misuse, neglect, accident, or unauthorized or improper use, installation, disassembly, repair or alteration by Buyer or its customers or agents.

For this limited warranty to apply, Buyer must, during the Warranty Period, notify EVnetics, LLC in writing upon discovery of any defects or non-conformities in the Product, explaining in reasonably sufficient detail the alleged defect or nonconformity covered by this limited warranty, and request an RMA number. No Products shall be returned to EVnetics, LLC for warranty services without an RMA number issued by EVnetics, LLC. Any Products returned under this limited warranty shall be shipped to EVnetics, LLC's plant at Buyer's expense. EVnetics, LLC will pay return freight only if warranty services are made under the terms hereof and Buyer must pay freight and handling costs for return of Product if warranty services are not made. For specific instructions on providing notice of defective Products, RMA requests, and return of defective Products, please see the instructions and contact information at www.evnetics.com. EVnetics, LLC will notify Buyer in the event the Products are not subject to warranty services, and unless instructions as to the disposition of such Products are received from Buyer within fourteen (14) days of such notification, the Products will be returned to Buyer, freight collect.

Limitation of Remedies. Buyer's sole and exclusive remedy and EVnetics, LLC's sole and exclusive obligation, under this warranty shall be, at EVnetics, LLC's option, either to repair or replace, or refund the purchase price of, any defective Products. In no event shall EVnetics, LLC be liable hereunder for any labor costs incident to the replacement of any defective Product. Any repaired or replaced Product will be warranted for the remainder of the original warranty period or thirty (30) days following delivery thereof, whichever is longer.

EXCEPT FOR THE EXPRESS WARRANTY SET FORTH ABOVE, EVnetics, LLC MAKES NO OTHER WARRANTIES OR GUARANTEES REGARDING THE PRODUCT, WHETHER EXPRESS, ORAL, IMPLIED, STATUTORY, ARISING BY OPERATION OF LAW, OR OTHERWISE. EVnetics, LLC HEREBY EXPRESSLY DISCLAIMS ALL IMPLIED WARRANTIES OR WARRANTIES OTHERWISE ARISING BY OPERATION OF LAW, INCLUDING THE IMPLIED WARRANTIES OF TITLE, MERCHANTABILITY, FITNESS FOR A PARTICULAR PURPOSE, AND NON-INFRINGEMENT OF THIRD PARTY RIGHTS. THE EXPRESS WARRANTY IN SECTION 8 SHALL EXTEND TO BUYER ONLY AND NOT TO BUYER'S CUSTOMERS, AFFILIATES OR SECONDARY PURCHASERS. BUYER, ITS CUSTOMERS, AND AFFILIATES ARE NOT AUTHORIZED TO MAKE, AND SHALL BE PROHIBITED FROM MAKING, ANY WARRANTY OR REPRESENTATION ON BEHALF OF EVnetics, LLC CONCERNING THE PRODUCTS. BUYER ACKNOWLEDGES AND AGREES THAT THE PRODUCTS OF EVnetics, LLC HAVE NOT BEEN DESIGNED, TESTED, OR MANUFACTURED FOR USE OR RESALE IN APPLICATIONS WHERE THE FAILURE, MALFUNCTION, OR ANY INACCURACY OF THE PRODUCTS CARRIES A RISK OF DEATH OR SERIOUS BODILY INJURY OR ENVIRONMENTAL DAMAGE. BUYER WILL BE SOLELY RESPONSIBLE FOR AND WILL INDEMNIFY, DEFEND, AND HOLD HARMLESS EVnetics, LLC AGAINST ANY AND ALL LIABILITIES, DAMAGES, COSTS AND EXPENSES RELATED TO ANY WARRANTIES WITH RESPECT TO THE PRODUCTS OTHER THAN THOSE EXPRESSLY PROVIDED BY EVnetics, LLC IN SECTION 8, AND TO ANY USE OF THE PRODUCTS OR RESALE IN APPLICATIONS FOR WHICH THE PRODUCTS WERE NOT DESIGNED, TESTED OR MANUFACTURED BY EVnetics, LLC.